



P5151 SERIES

PUMPS AND MOTORS



5151 SERIES FEATURES

- ❑ Dual Ported - Standard 1-1/2" NPT rear ports and up to 1-1/2" NPT side ports
- ❑ Pressure balanced wear plates maintain high pump efficiency throughout all operating ranges
- ❑ Bi-Rotational Pump/Motor designed to fit a wide variety of applications
- ❑ Doweled and high strength cast iron construction
- ❑ High strength alloy steel gear and shaft sets
- ❑ Standard SAE "B" 2 & 4 Bolt mounting flange
- ❑ Standard SAE "B" Spline Output Shaft
- ❑ Cubic inch displacements from 4.50 through 7.07
- ❑ Working pressure up to 3000 PSI
- ❑ Speeds up to 3000 RPM
- ❑ Porting, mounting, and shaft options available
- ❑ 100% factory tested



The Sensible Choice

Dimensional Data (inches)

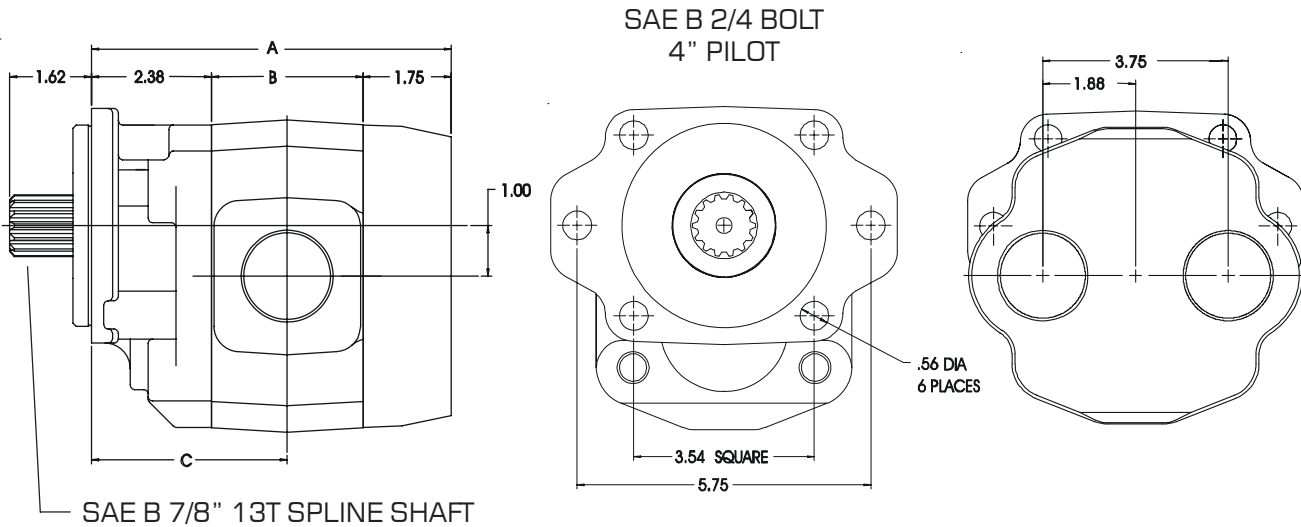

Product Information

Type II (shown above)	A	B	C	Displ. Cu. In.	Theo. GPM 1000 RPM	Avg. GPM 1000 RPM	NPT Ports		Max RPM#	Peak PSI
							Side	Rear		
(P)5151A224AAXK17-54	6.63	2.50	3.63	4.50	19	17.5	1-1/4	1-1/2	3000	3000
(P)5151A224AAXK20-54	6.88	2.75	3.75	5.15	23	19.5	1-1/4	1-1/2	3000	3000
(P)5151A224AAXQ22-54	7.13	3.00	3.88	5.70	25	21.0	1-1/2	1-1/2	3000	3000
(P)5151A224AAXQ25-54	7.38	3.25	4.00	6.43	27	23.5	1-1/2	1-1/2	3000	3000
(P)5151A224AAXQ27-54	7.63	3.50	4.12	7.07	30	26.4	1-1/2	1-1/2	2400	2500

(P) for Pump (M) for Motor
Maximun Inlet Vacuum 5 In. Hg.

Type I*	A	B	C	Displ. Cu. In.	Theo. GPM 1000 RPM	Avg. GPM 1000 RPM	NPT Ports		Max RPM#	Peak PSI
							Side	Rear		
(P)5151A***AAXK17-14*	7.63	2.50	4.63	4.50	19	17.5	1-1/4	1-1/2	3000	3000
(P)5151A***AAXK20-14*	7.88	2.75	4.75	5.15	23	19.5	1-1/4	1-1/2	3000	3000
(P)5151A***AAXQ22-14*	8.13	3.00	4.88	5.70	25	21.0	1-1/2	1-1/2	3000	3000
(P)5151A***AAXQ25-14*	8.38	3.25	5.00	6.43	27	23.5	1-1/2	1-1/2	3000	3000
(P)5151A***AAXQ27-14*	8.63	3.50	5.12	7.07	30	26.4	1-1/2	1-1/2	2400	2500

(P) for Pump (M) for Motor
* Consult the Design Engineer's Handbook or the Permco Code Books for more details and options for Type I Shaft End Covers and Shafts.
Maximun Inlet Vacuum 5 In. Hg.

Permco
1500 Frost Rd.
P. O. Box 2068
Streetsboro, OH 44241

Phone 330-626-2801
Fax 330-626-2805
e-mail info@permco.com
www.permco.com

Permco Hydraulik AG
P. O. Box 553
6343 Rotkreuz
Switzerland
e-mail heinzsm@permco.com

Permco (TianJin) Hydraulics Inc., Ltd.
236 Jinbindadao Free Trade Zone
TianJin Port, China
www.permcotj.com
e-mail technic@permcotj.com